

PAPER CRAFT

<http://www.canon.com/c-park/en/>



View of completed model

Assembly Instructions: Five A4 sheets (No.1 to No.5)

*Build the model by carefully reading the Assembly Instructions, in the parts sheet page order.

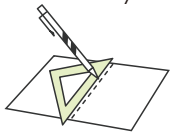

*Hint: Trace along the folds with a ruler and an exhausted pen (no ink) to get a sharper, easier fold.

Assembly Instructions



Mountain fold(dotted line)
Make a mountain fold.



Valley fold(dashed and dotted line)
Make a valley fold.

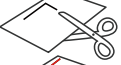

Scissors line(solid line)
Cut along the line.



Cut in line(solid line)
Cut along the line.

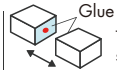

Glue
The glue spot(colored dot) shows where to apply the glue.

● Glue spot(Red dot)
Glue parts with the same number together.

● Glue spot(Green dot)
Glue within the same part.

● Glue spot(Blue dot)
Glue to the rear of the other part.

Tools and materials



Scissors, set square, glue(We recommend stick glue), pencil, used ballpoint pen, toothpicks, tweezers, (useful for handling small parts)

Assembly tip



Before gluing, create the paper along mountain fold and valley fold lines and make sure rounded sections are nice and stiff.

Caution



Glue, scissors and other tools may be dangerous to young children so be sure to keep them out of the reach of young children.

Before starting assembly: Writing the number of each section on its back side before cutting out the sections is highly recommended. (* This way, you can be sure which section is which even after cutting out the sections.)

Indicates where sections should be glued together.
 Indicates where to insert sections. Do not glue the sections together.

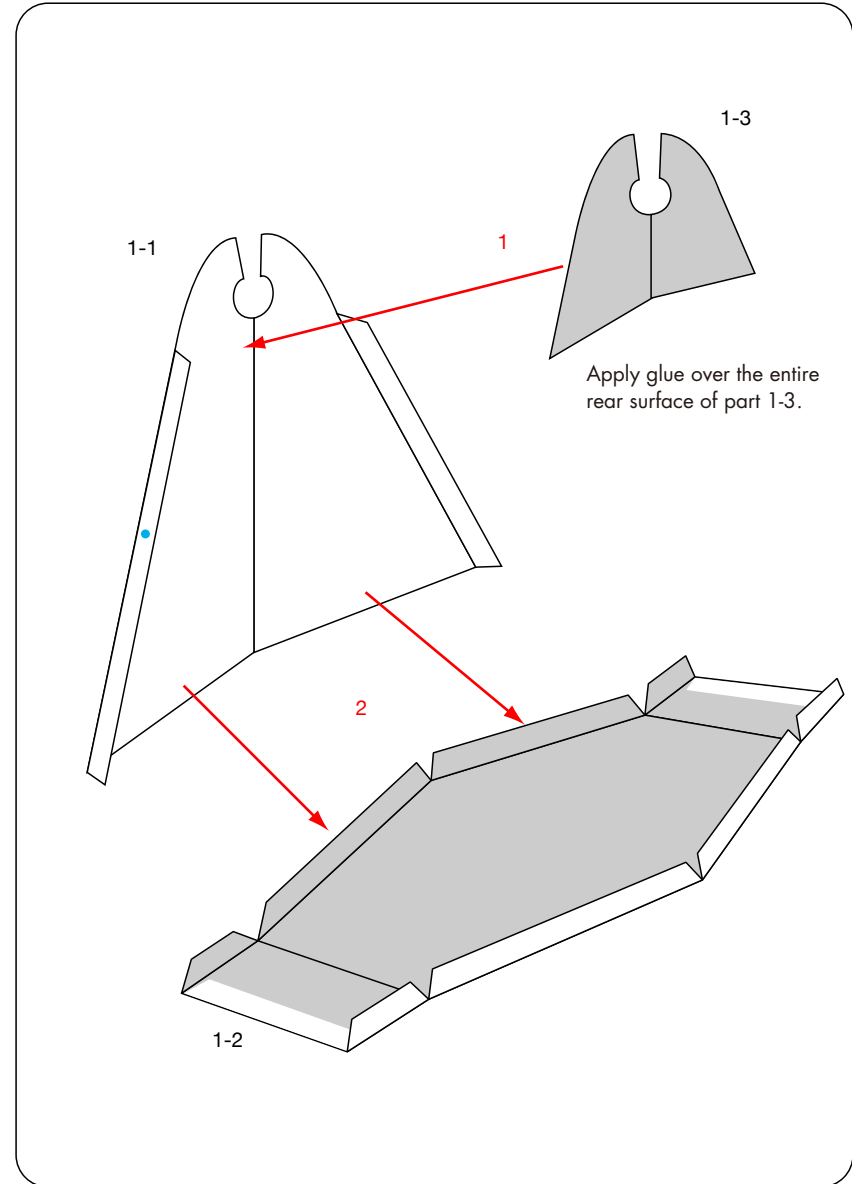

Flip Animation: Assembly Instructions

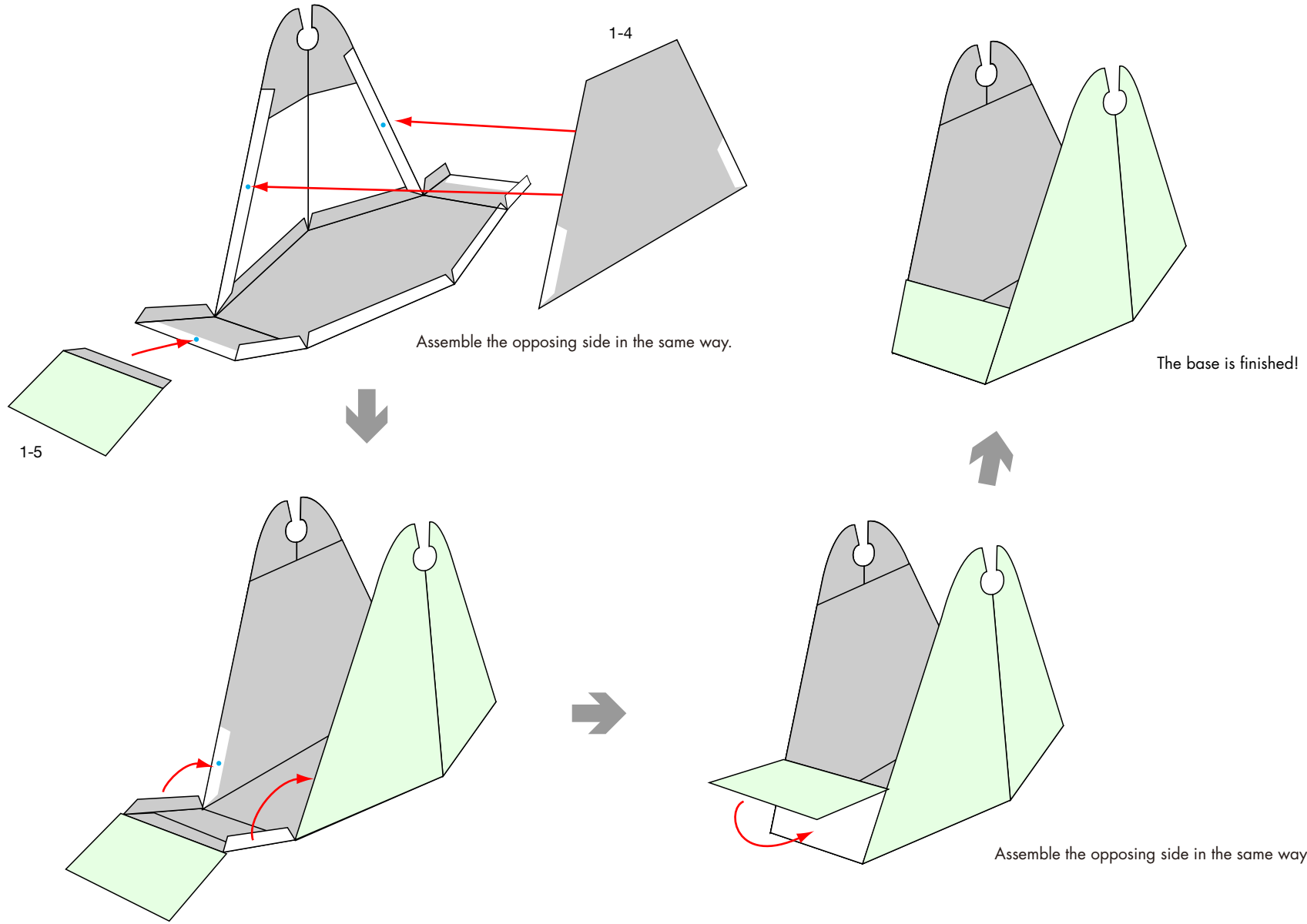

Flip Animation: Assembly Instructions

2-1-1

2-1-2

View from above

Glue the rear surfaces together so that the cut lines do not overlap.

2-1

After attaching these parts, cut notches along the red lines in the diagram for part 2-1-2.

Build the same part again to make a total of two identical parts.

2-4

Assemble parts 2-5 and 2-6 in the same way.

2-2-1

2-2-2

2-3-1

2-3-2

2-7

Make creases.

Return the creases to their original positions.

Flip Animation: Assembly Instructions

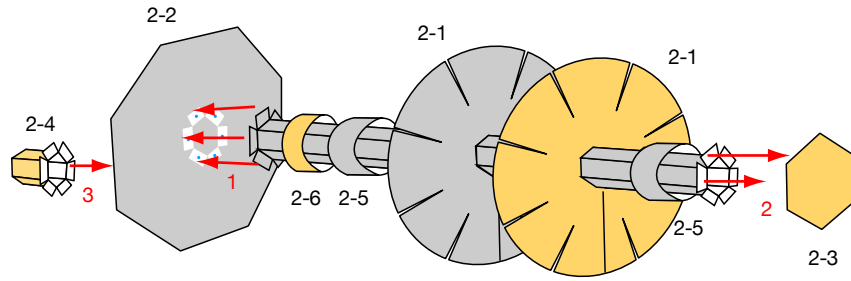

Axle cross-section

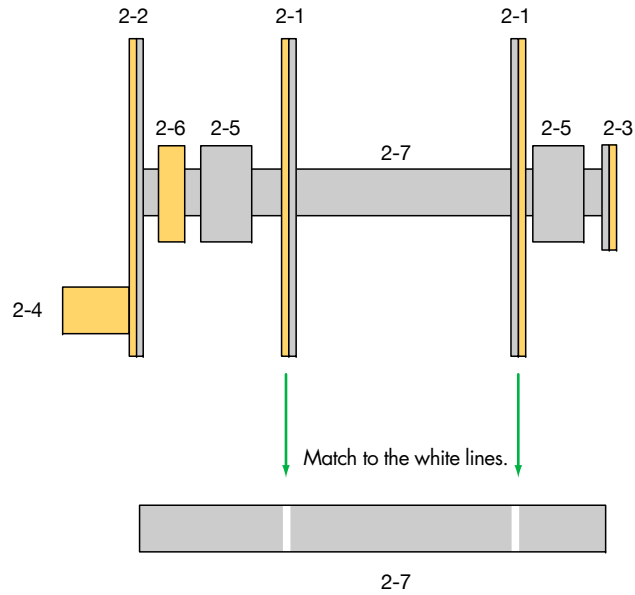

Animation A, B, C

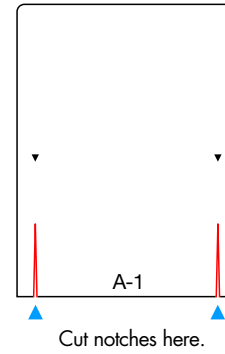

Assembling your chosen animation on the axle

First, place the axle before you so that the handle is on the right.

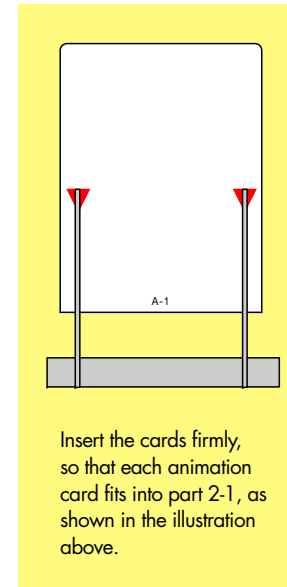
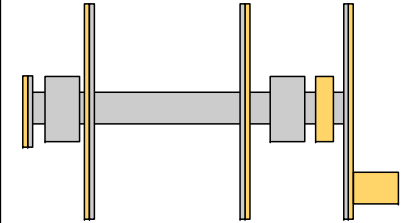

Insert your chosen animation, one card at a time.

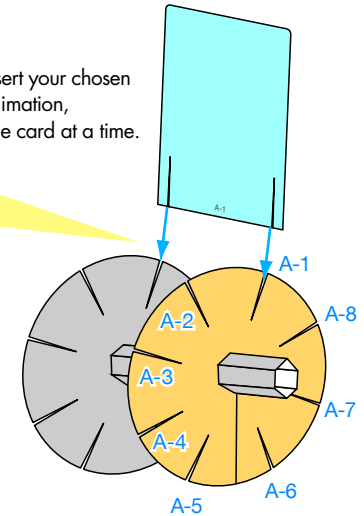

Flip Animation: Assembly Instructions

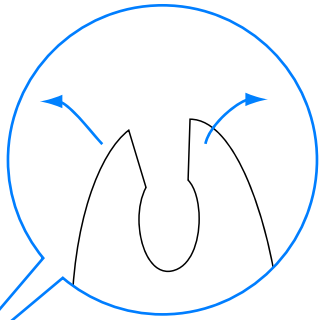
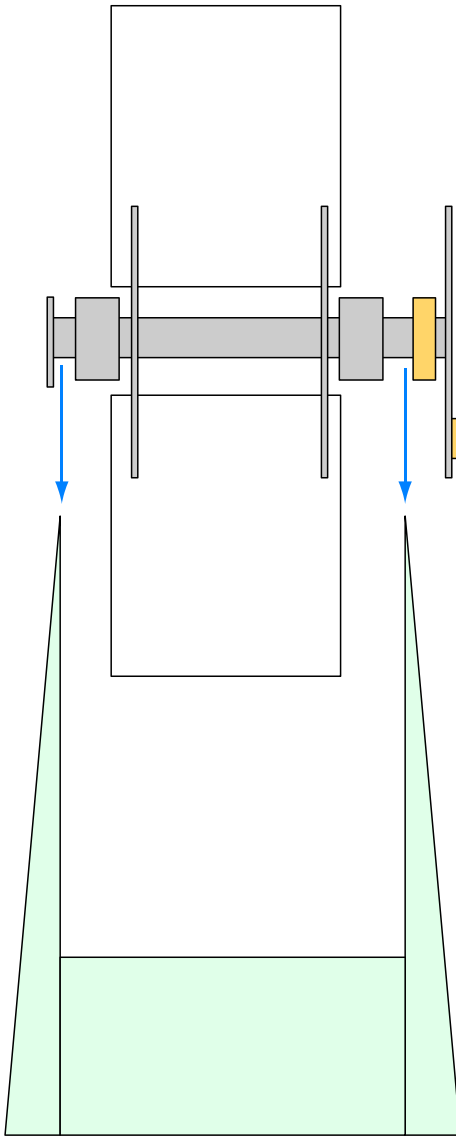

Position the axle by bending the paper of the base back to widen the opening for insertion.

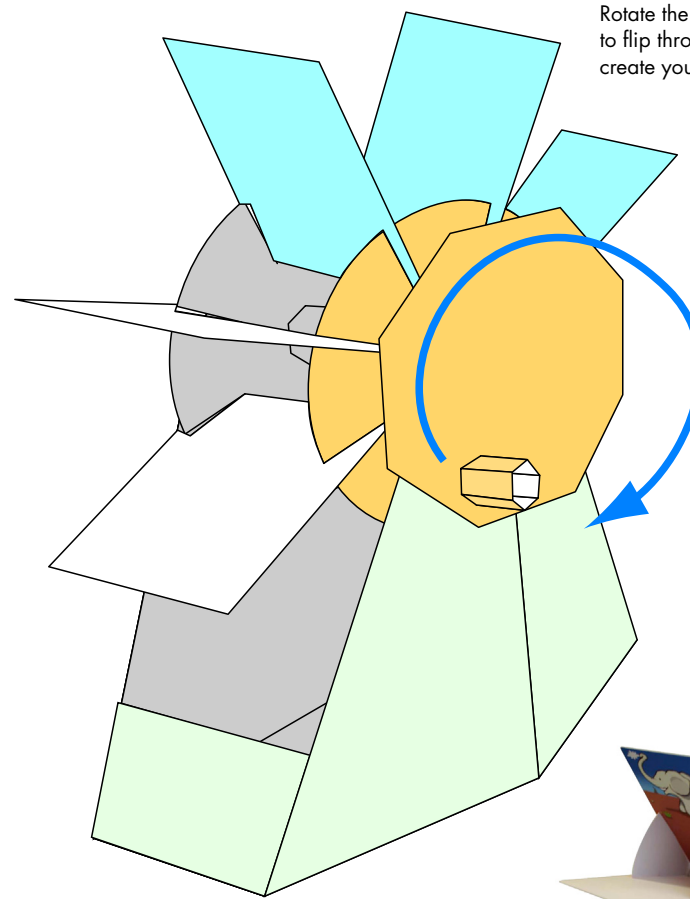

Rotate the handle clockwise to flip through the cards and create your animation.

Use your hand to hold the left side lightly.



Finished!